

US 8VGCE XC2, US 8VGC XC2, US 8VGCHC XC2

DATA SHEET Deep Cycle 8 -Volt



US 8VGCE XC2



US 8VGC XC2
(US 8VGCi XC2 cover option also available)



US 8VGCHC XC2



Application: Wherever Deep Cycle 8-volt batteries are needed.

Dimensions: 10-1/4 (260)L x 7-1/8 (181)W x 11-1/4 (286)H

Type: Flooded Lead Acid (FLA) non-sealed.

Case material: Polypropylene / Heat Sealed



US 8VGCE XC2, US 8VGC XC2, US 8VGCHC XC2 - SPECIFICATIONS

BCI Group Size	Model	1-hr Rate	2-hr Rate	5-hr Rate	6-hr Rate	10-hr Rate	20-hr Rate	48-hr Rate	72-hr Rate	100-hr Rate	Voltage	Standard Terminal Type	AMP HOURS (20 HR. RATE)	MINUTES @ 75 AMPS	MINUTES @ 56 AMPS	MINUTES @ 25 AMPS	Length	Width	Height	Wet Weight Lbs (kg)
GC8	US 8VGCE XC2	90	105	129	132	142	155	164	169	172	8	UTL	155	75	110	312	10-1/4 (260)	7-1/8 (181)	11-1/4 (286)	60 (27)
GC8	US 8VGC XC2	96	111	133	138	151	170	180	185	189	8	Molded-In UTL	170	82	118	325				62 (28)
GC8	US 8VGCHC XC2	109	124	147	152	164	183	194	199	203	8	UTL	183	95	136	365				67 (30)

TERMINAL OPTIONS:



Available only on US 8VGC

VENT CAP OPTIONS:



SpeedCap®
(not available on US 8VGCi)



Bayonet

CHARGING INSTRUCTIONS:

Following is the charging recommendation and charging profile using 2 stage chargers for US Battery deep cycle products. *Equalization and float charge modes are not considered to be one of the stages in a charging profile.

- Bulk Charge** Constant current @~10% of C/20 Ah in amps to 2.45+/-0.05 volts per cell (e.g. 7.35 volts +/-0.15 volts per 6 volt battery)
- Absorption Charge** Constant voltage (2.45+/-0.05 vpc) to 3% of C/20 Ah in amps then hold for 2-3 hours and terminate charge. Charge termination can be by maximum time (2-4 hr) or dV/dt (4 mv/cell per hour)
 - (Optional Float Charge) Constant voltage 2.17 vpc (6.51 volts per 6 volt battery) for unlimited time
 - Equalization Charge Constant voltage (2.55+/-0.05 vpc) extended for 1-3 hours after normal charge cycle (repeat every 30 days)

Notes: Charge time from full discharge is 9-12 hours.
Absorption charge time is determined by the battery but will usually be ~3 hours at 2.45 volts per cell.
Float time is unlimited at 2.17 volts per cell.
Specific gravity at full charge is 1.270 minimum

Battery temperature adjustment: reduce the voltage by 0.028 Volts per cell for every 10°F above 80°F, increase by the same amount for temperatures below 80°F.

Deep cycle batteries need to be equalized periodically. Equalizing is an extended, low current charge performed after the normal charge cycle. This extra charge helps keep all cells in balance. Actively used batteries should be equalized once per month. Manually timed chargers should have the charge time extended approximately 3 hours. Automatically controlled chargers should be unplugged and reconnected after completing a charge.

US 8VGCE XC2, US 8VGC XC2, US 8VGCHC XC2

DATA SHEET Deep Cycle 8 -Volt

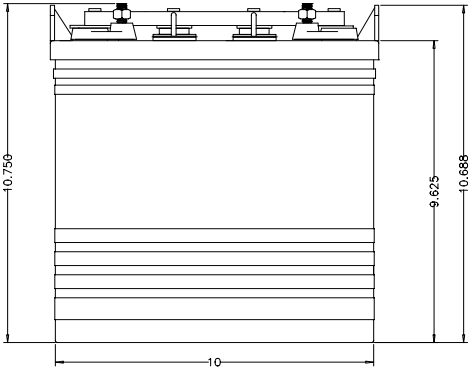
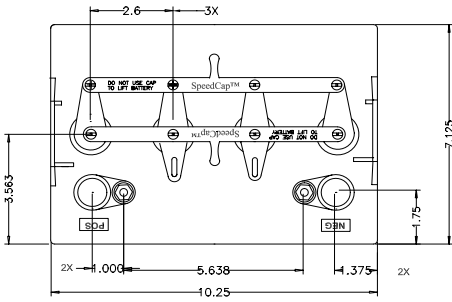

U.S. Battery Recommended Terminal Torque and Connection Hardware

U.S. Battery Terminal Type	Recommended Torque (in-lb)	Recommended Torque (ft-lb)	Recommended Connection Hardware
UTL	95-105	7.9-8.8	¹ SS Hexnut with Lock Washer
UT	95-105	7.9-8.8	¹ SS Hexnut with Lock Washer
Flat Block	95-105	7.9-8.8	¹ SS Hexnut with Lock Washer
Dual	95-105	7.9-8.8	^{1,6} SS Hexnut with Lock Washer
DC Marine	95-105	7.9-8.8	² SS Hexnut with Lock Washer
Off-Set "S"	100-120	8.3-10	³ Zn or SS Bolt w/Hexnut & Lock Washer
Flag	100-120	8.3-10	⁴ Zn or SS Bolt w/Hexnut & Lock Washer
Large "L"	100-120	8.3-10.0	⁴ Zn or SS Bolt w/Hexnut & Lock Washer
Small "L"	100-120	8.3-10.0	⁴ Zn or SS Bolt w/Hexnut & Lock Washer
Bus Lug	120-180	10.0-15.0	⁵ SS Hexnut with Lock Washer
SAE	50-70	4.2-5.8	⁶ No Hardware Supplied

Proper connection is to position a lock washer between the nut and the connector (never between the connector and lead terminal) and apply the recommended torque or enough torque to completely compress the lock washer without deforming the lead terminal.

- ¹Stainless Steel Hexnut with Stainless Steel Split-Ring Lock Washer (5/16" Positive & Negative)
- ²Stainless Steel Hexnut with Stainless Steel Split-Ring Lock Washer (3/8" Positive & 5/16" Negative)
- ³Square-Head, SS or Zinc-Plated Bolt with SS or Zinc-Plated Hexnut & Split-Ring Lock Washer
- ⁴Square-Head or Hex-Head, SS or Zinc-Plated Bolt with SS or Zinc-Plated Hexnut & Split-Ring Lock Washer
- ⁵Stainless Steel Hexnut with SS Split-Ring Lock Washer (1/2" Positive or 3/8" Positive & 3/8" Negative)
- ⁶No Hardware Supplied - Application Uses SAE Clamp for Positive & Negative Tapered Post

Note: The use of flanged nuts and other types of nuts with captive washers or other hardware not listed above is not recommended by US Battery and their use may void the battery warranty.

EXPECTED LIFE CYCLES VS. DOD (XC, XC2 & AGM)

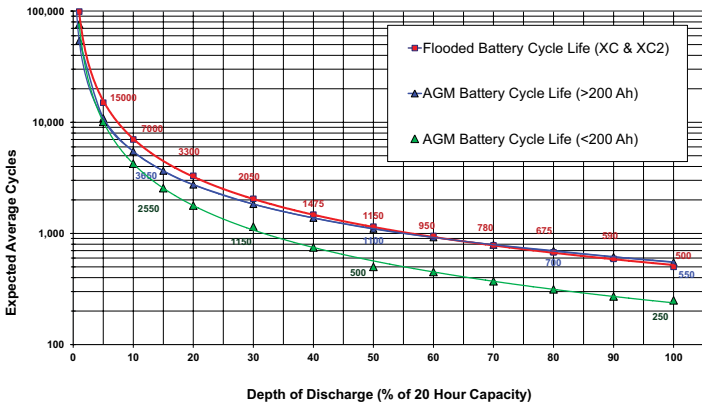

US 8VGCE XC2, US 8VGC XC2, US 8VGCHC XC2 - DISCHARGE TIME VS CURRENT @80° F

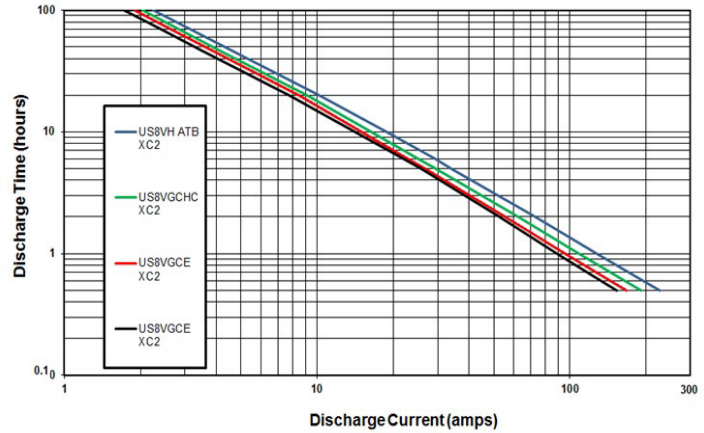

BATTERY % CAPACITY VS TEMP

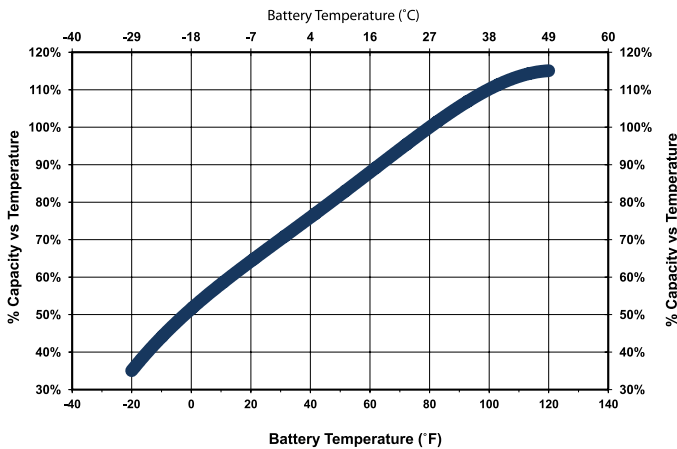

U.S. Battery Operating Temperature Guidelines

For charging, we recommend staying within 0°F to 120°F (-18 to 49°C) to avoid charging frozen batteries at low temperature or going into thermal runaway at high temperature.

For discharging, we recommend -20°F to 120°F (-29 to 49°C). Batteries discharged at temperatures below 32°F (0°C) should be recharged immediately to avoid freezing.

Batteries discharged at temperatures above 120°F (49°C) should be allowed to cool before recharging.

Extreme temperatures can substantially affect battery performance and charging. Cold reduces battery capacity and retards charging. Heat increases water usage and can result in overcharging. Very high temperatures can cause "thermal run-away" which may lead to an explosion or fire. If extreme temperature is an unavoidable part of an application, consult a battery/charger specialist about ways to deal with the problem.

Data references within this publication are nominal and should not be considered or construed as maximum or minimum values for specifications or for final design. Data for this product type and model may vary from what is shown in this publication, and U.S. Battery Mfg., Co. makes no warranties, expressed or implied based on the data within this publication.

©2013 U.S. Battery Mfg., Co. All rights reserved. U.S. Battery is not liable for damages that may occur from any information provided in or omitted from this publication, under any circumstances. U.S. Battery Mfg., Co. reserves the right to make changes or adjustments to this publication at any time without notices or obligations.

